

4

3

2

1

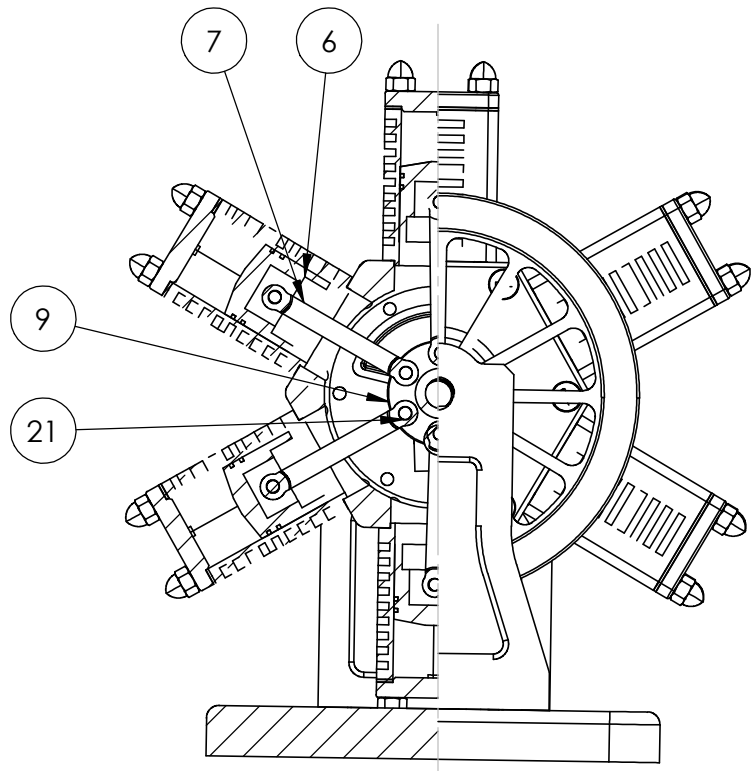

SECTION A-A  
SCALE 1 : 3

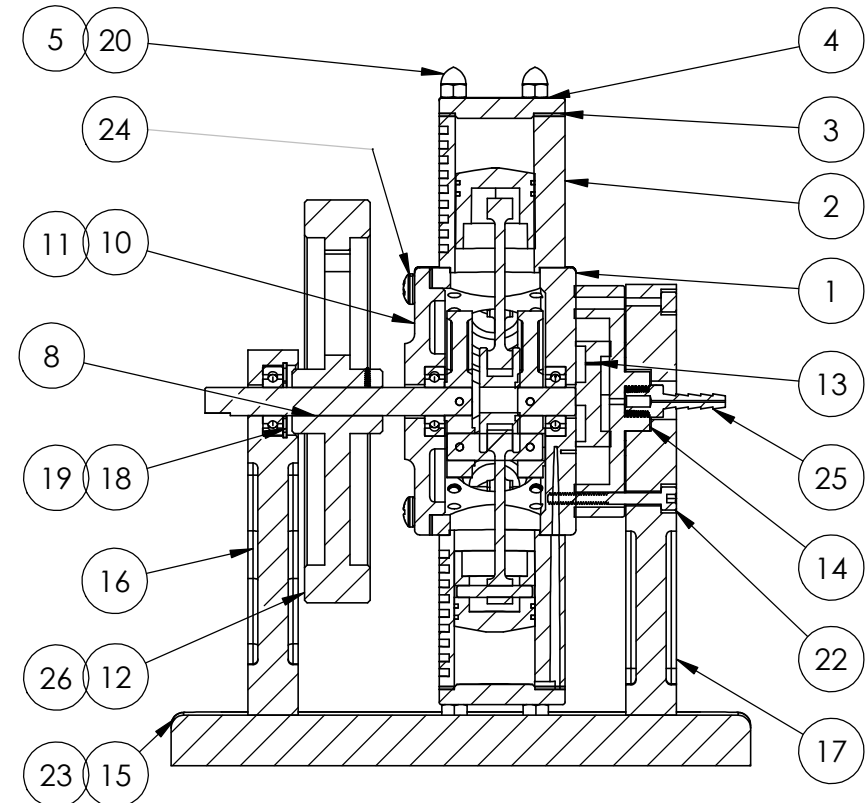

SECTION B-B  
SCALE 1 : 3

ITEM NO.	PART	DESCRIPTION	MATERIAL	QTY.
1	CRANKCASE		6061 ALLOY	1
2	CYLINDER		6061 ALLOY	6
3	CYLINDER HEAD GASKET		RUBBER	6
4	CYLINDER HEAD		6061 ALLOY	6
5	CYLINDER HEAD BOLT		STAINLESS STEEL	24
6	ASSEMBLY PISTON		VARIES	6
7	CONNECTING ROD		6061 ALLOY	6
8	ASSEMBLY CRANKSHAFT		VARIES	1
9	CONNECTING ROD HUB		BRASS, SOFT YELLOW	1
10	CRANKCASE COVER		6061 ALLOY	1
11	CRANKCASE GASKET		RUBBER	1
12	FLYWHEEL		STAINLESS STEEL	1
13	VALVE		BRASS	1
14	VALVE HOUSING		6061 ALLOY	1
15	STAND		WOOD (OAK)	1
16	BEARING HOLDER		6061 ALLOY	1
17	BEARING STAND		6061 ALLOY	1
18	DIN 472 - 28X1.2	RETAINING RINGS FOR BORES	STEEL, MILD	1
19	DIN 625 SKF - 6001	SINGLE ROW BALL BEARINGS	STEEL, MILD	3
20	DIN 1587 - M6	HEX DOMED CAP NUTS	STEEL, MILD	24
21	ISO 2338 - 5 H8X16	PARALLEL PINS	STAINLESS STEEL	6
22	ISO 4726 - M6X45	HEX SOCKET HEAD CAP SCREW	STAINLESS STEEL	6
23	ISO 4762 - M10X25	HEX SOCKET HEAD CAP SCREW	STAINLESS STEEL	4
24	ISO 7046 M6X16-4.8	CROSS RECESSED PAN HEAD MACHINE SCREW	STAINLESS STEEL	6
25	PARKER HOSE PIPE	HOSE BARB TO MALE PIPE 125HBL	BRASS, SOFT YELLOW	1
26	ISO 4028 - M5X8	HEX SOCKET SET SCREWS	STAINLESS STEEL	1
27	SILENCER M8		BRASS, SOFT YELLOW	1

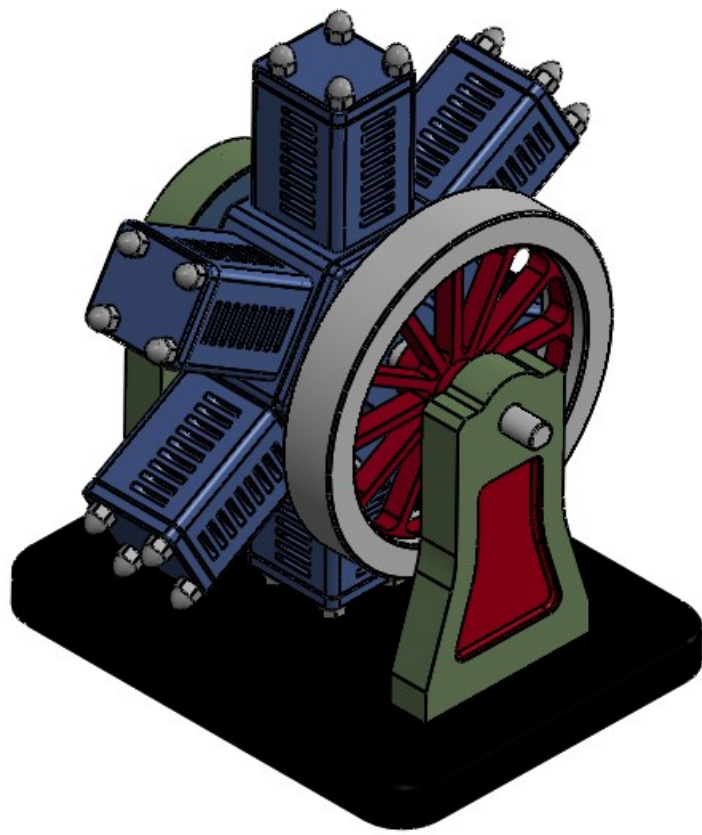
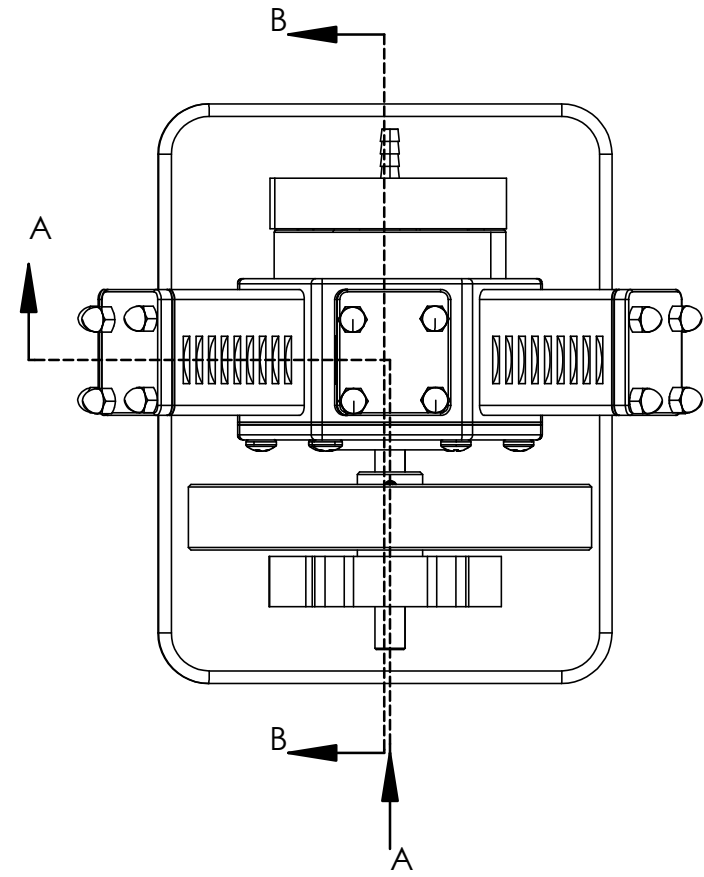

UNLESS OTHERWISE SPECIFIED:

DIMENSIONS ARE IN INCHES  
TOLERANCES:  
FRACTIONAL ±  
ANGULAR: MACH ± BEND ±  
TWO PLACE DECIMAL ±  
THREE PLACE DECIMAL ±

INTERPRET GEOMETRIC TOLERANCING PER:  
MATERIAL  
FINISH

DO NOT SCALE DRAWING

NAME	ADL	DATE	11/28/20
DRAWN			
CHECKED			
ENG APPR.			
MFG APPR.			
Q.A.			

COMMENTS

Delightful Designs

TITLE: **Pneumatic Radial Engine**

SIZE	DWG. NO.	REV
<b>B</b>	<b>1DT1000A</b>	

SCALE: 1:4 WEIGHT: SHEET 1 OF 1

B

B

A

A

4

3

2

1

